

Instruction Manual for ColdPack EYP-MNT-0000-00000-0000-CLP01-0000

TO-3 Adapter with integrated
Thermoelectric Cooler



Contact:

eagleyard Photonics GmbH
Rudower Chaussee 29
12489 Berlin

Tel (030) 6392 4520
Fax (030) 6392 4529
Email info@eagleyard.com

Revision: 3

Date: May 2016

Dear Customer,

Welcome to the eagleyard community!

We have designed this product to be easy to use and reliable so that you can focus on your work. Should you have questions or need advice on how to integrate it into your setup, please do not hesitate to ask. We will provide you with quick and competent help through our service staff and product managers.

You can contact us in the following ways:

- internet: www.eagleyard.com. In our support section you can find a list of frequently asked questions and a service contact form
- email: info@eagleyard.com
- phone: +49. 30. 6392 4520

Our customers may also contact eagleyards Distributors. The contact details are listed at our website: www.eagleyard.com/en/distributors/

Please have your product-ID/serial number ready when contacting us so we can quickly retrieve all relevant information.

As we are constantly improving our products, we greatly value all customer feedback. We encourage you to tell us what you like about our products as well as any suggestions for improvement.

Best regards,

Your Sales Team
eagleyard Photonics GmbH

Instruction Manual

Content

- 1 General**
 - 1.1 Specifications
- 2 Mounting of the Laser Diode**

3 Pin Assignment

3.1 Pinning and Soldering Example

4 ColdPack Main Dimensions

5 Guarantee and Service

Safety Instructions

Read this instruction carefully before unpacking to avoid damage of the diode laser. The laser should be handled and operated by qualified personnel only.

The diode laser is a class 4 laser product according IEC Standard (laser class IV acc. FDA CDRH regulations).

This includes safety regulations for eye and personnel protection that must be observed.

- The laser should be operated with all covers in place.
- Users are strongly recommended to enclose the laser beam where reasonably practicable.
- The access to the laser has to be limited to trained staff.
- Because of the high output power the laser could burn clothing, paper or ignite flammable substances. The focussed beam is able to melt glass or metal shields.
- The laser beam is guided by a glass fiber. Spooled glass fibers are under tension. Use protective eye wear and exercise care during handling.

1 General

In a variety of applications, simple heat sinking of a laser diode only is not sufficient. In more sincere cases, even full thermal control of the laser diode might be requested. Today, standard laser diodes are mostly built into 9 mm (SOT-148) or 5.6 mm (TO-18 or MG) packages, and are not equipped with integrated coolers. To overcome these limitations, eagleyard Photonics GmbH has developed its patented COLD- PACK solution. This device is an adapter-kit allowing for incorporation of standard 9 or 5.6 mm laser diode housings into a TO-3 style package. Four thermoelectric elements serve to stabilize the laser temperature or rapidly heat/cool the diode. The actual temperature can be monitored by means of an integrated thermistor (10 k NTC). The built-in laser diode can easily be changed.

The COLDPACK enables to shift the emission spectrum of a laser diode (typical temperature dependence of the wavelength of GaAs diodes: 0.3 nm/°C). When used in an external cavity configuration, the accessible wavelength range may thus be increased while maintaining continuous single-frequency operation of the laser. Moreover, the COLDPACK lends itself for convenient frequency tuning of Distributed Feedback (DFB) laser diodes. The thermal isolation function of the thermoelectric coolers also ensures an electrical isolation of the laser diode to the outer housing.

CAUTION! When mounting COLDPACK, make sure that the TO-3 adapter has proper thermal contact to your external heat sink in order to achieve good long term stability.

1.1 Specifications

The COLDPACK includes 4 thermoelectric modules in series:

Q_{max} : 11.2 W
 T_{min} : 0 °C
 T_{max} : 50 °C
 U_{max} : 17.2 V
 I_{max} : 1.2 A

Resistance R of Thermistor 10k, NTC

$$R = R_0 \times e^{\frac{\beta}{T} - \frac{\beta}{T_0}}$$

$$R = R_0 \times e$$

$R_0 = 10 \text{ k}\Omega$, $\beta = 3895 \text{ K}$, $T_0 = 298 \text{ K}$, $T = \text{temperature in Kelvin}$

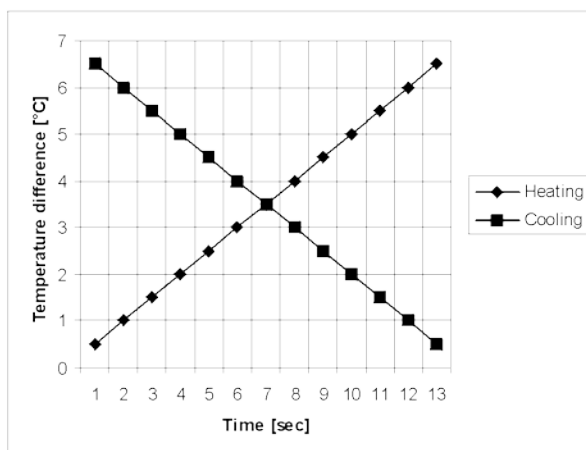

Figure 1 Examples of rapid linear temperature scans with COLDPACK, realizing 5 °C/10 s in heating/cooling operation

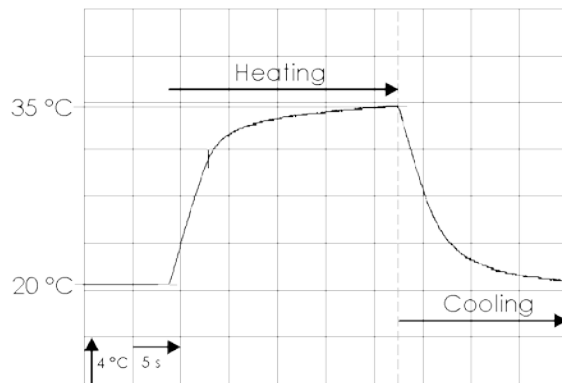

Figure 2 Temperature Response of COLDPACK, operated with a Toptica DTC 110 Temperature Controller (TEC Current 500 mA)

2

Mounting of the Laser Diode

CAUTION! The thermoelectric coolers of the COLDPACK are sensitive to mechanical stress. Please avoid any mechanical stress on these sensitive components and do not apply a torque exceeding 6 cNm on the screws. Laser Diodes are sensitive to electrostatic discharge (ESD). Electrical discharges might considerably affect the lifetime of a laser diode, even if a disturbance is not immediately noticeable. When mounting the laser diode be sure to wear a high-impedance grounding strip around the wrist at all times.

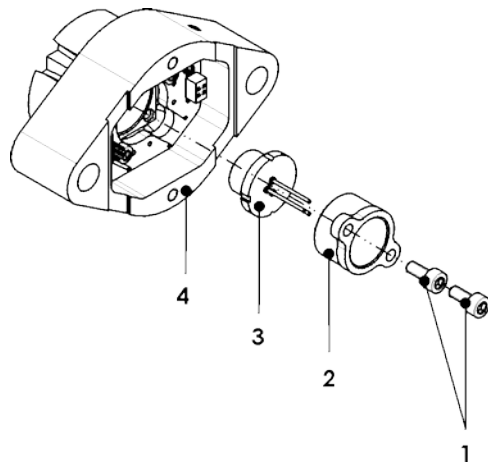

Figure 3 Fixation of the Laser Diode

The laser diode (3) is fixed to the COLDPACK (4) by a ring (2) and two Allen screws M1.6x3 mm (1).

1. Shorten the pins of the laser diode (3) to approx. 7 mm. Insert laser diode (3) into COLDPACK (4) and fix with ring (2) and screws (1) so that the orientation of the laser beam axes can be adjusted. The edge of the visible heat sink or the grooves in the housing of the laser diode can serve for orientation. Tighten screws (1).

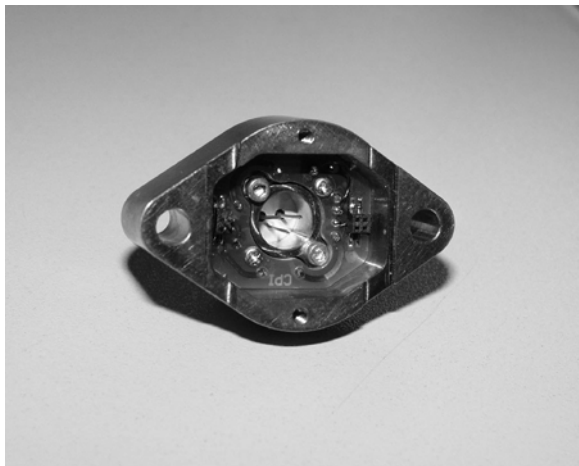

Figure 4 Laser Diode mounted in COLDPACK

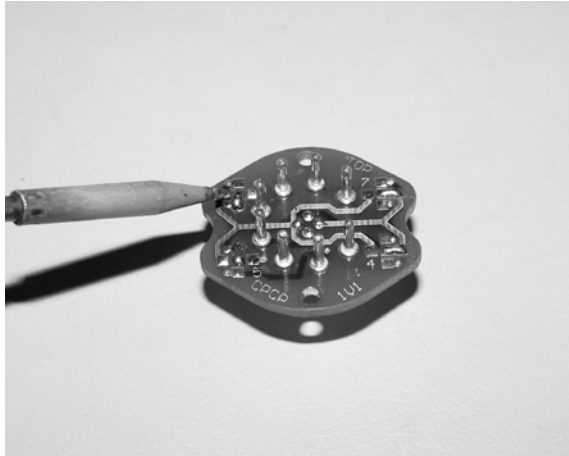

Figure 5 Setting the Soldering Pads at the Connector PCB

2. Set the soldering pads according to the specific laser diode. For detailed information see Paragraph 3.

NOTE! If the COLDPACK is delivered with a built-in laser diode, the soldering pads are set accordingly.

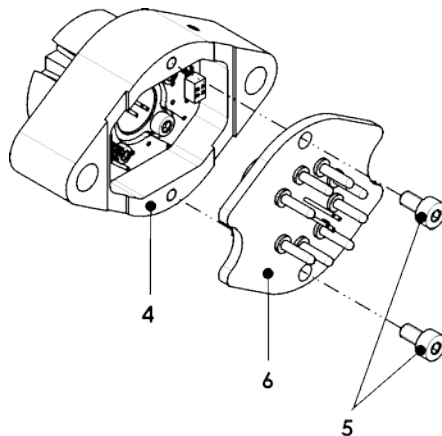

Figure 6 Fixation of the COLDPACK Connector PCB

3. Mount the connector PCB (6) to the COLDPACK (4). Take care that the two little plugs and sockets for the TEC connection and the pins of the laser diode fit exactly.
4. Fix the connector PCB (6) with two Allen screws M1.6 x 3 mm (5).

The pin assignment on the connector PCB is as follows.

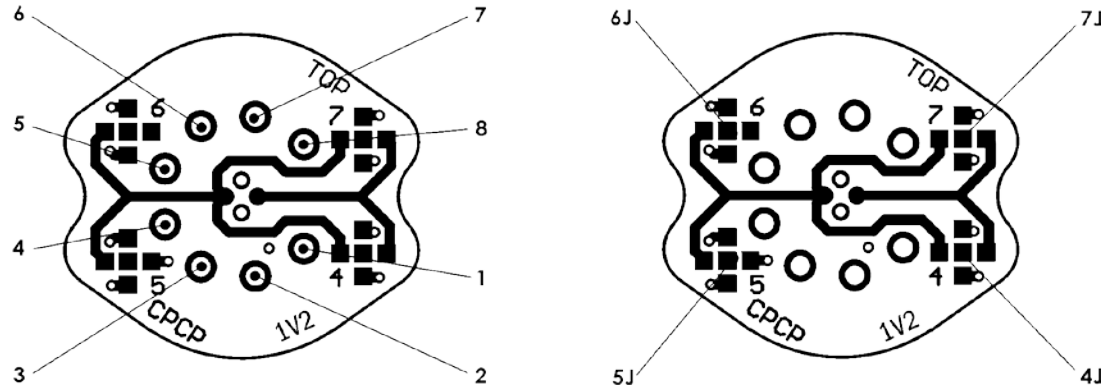

Figure 7 Pin assignment (left) and corresponding soldering pads (right)

Pin 1	TEC (+)	Pad 4J	Laser Diode cathode (-)
Pin 2	Thermistor 1	Pad 5J	Laser Diode anode (+)
Pin 3	Thermistor 2	Pad 6J	Monitor Photodiode anode
Pin 4	Laser Diode cathode (-)	Pad 7J	Monitor Photodiode cathode
Pin 5	Laser Diode anode (+)		
Pin 6	Monitor Photodiode anode		
Pin 7	Monitor Photodiode cathode		
Pin 8	TEC (-)		

Pins 4, 5, 6 and 7 are connected to the center pads 4J, 5J, 6J and 7J of the corresponding soldering pads.

The 4 outer pads of the soldering pads represent the 4 possible laser diode connector pins. Due to the variety of laser diode mounting orientations and the pin assignment of a specific laser diode, different pad solderings are possible. An example is shown in Figure 8.

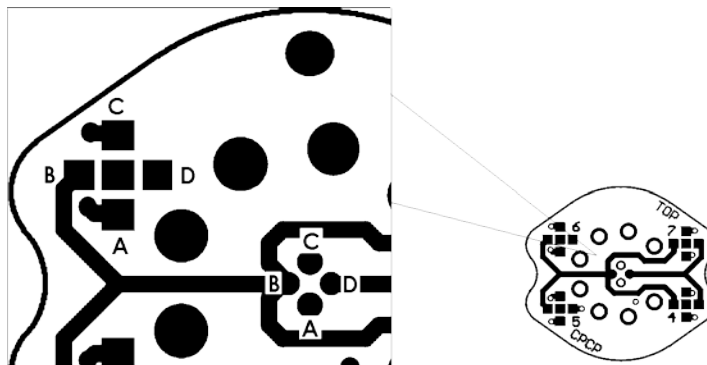

Figure 8 Laser Diode connector pins (center) and corresponding soldering pads

By soldering the 4 pads the user can connect a specific laser diode according to the manufacturer's data sheet.

3.1 Pinning and Soldering Example

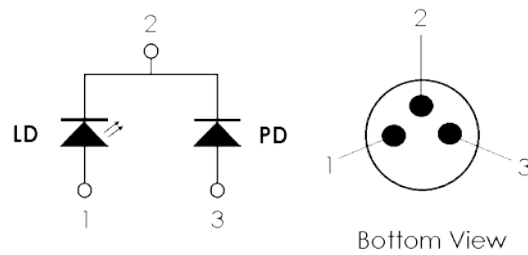

Figure 9 Schematics of a Laser Diode with integrated Photo Diode

Diode Pin 1 Laser Diode anode
 Diode Pin 2 Ground (Laser Diode and Photo Diode cathode)
 Diode Pin 3 Photo Diode anode

In our example the pins are soldered as follows:

Diode Pin 1 to connector C
 Diode Pin 2 to connector D
 Diode Pin 3 to connector A

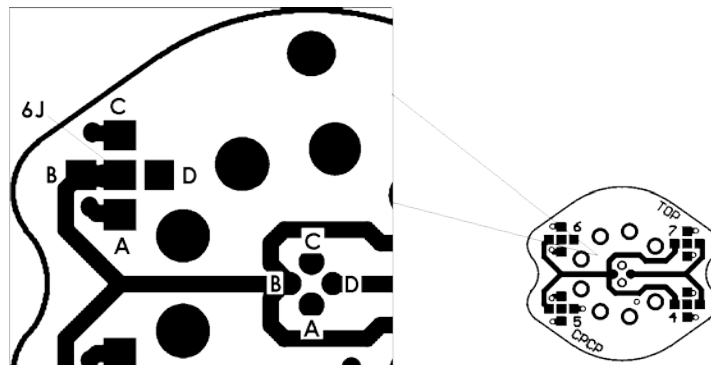

Figure 10 Laser Diode connector pins (center) and corresponding soldering pads

Referring to the pin assignment shown in Figure 7 one has to solder the pads to get the proper connections to the laser diode. In our example, the pads have to be soldered as follows:

Pad 4J	Laser Diode cathode (-), Case	soldered to	Pad D
Pad 5J	Laser Diode anode (+)	soldered to	Pad C
Pad 6J	Monitor PD anode	soldered to	Pad A
Pad 7J	Monitor PD cathode, Case	soldered to	Pad D

COLDPACK Main Dimensions

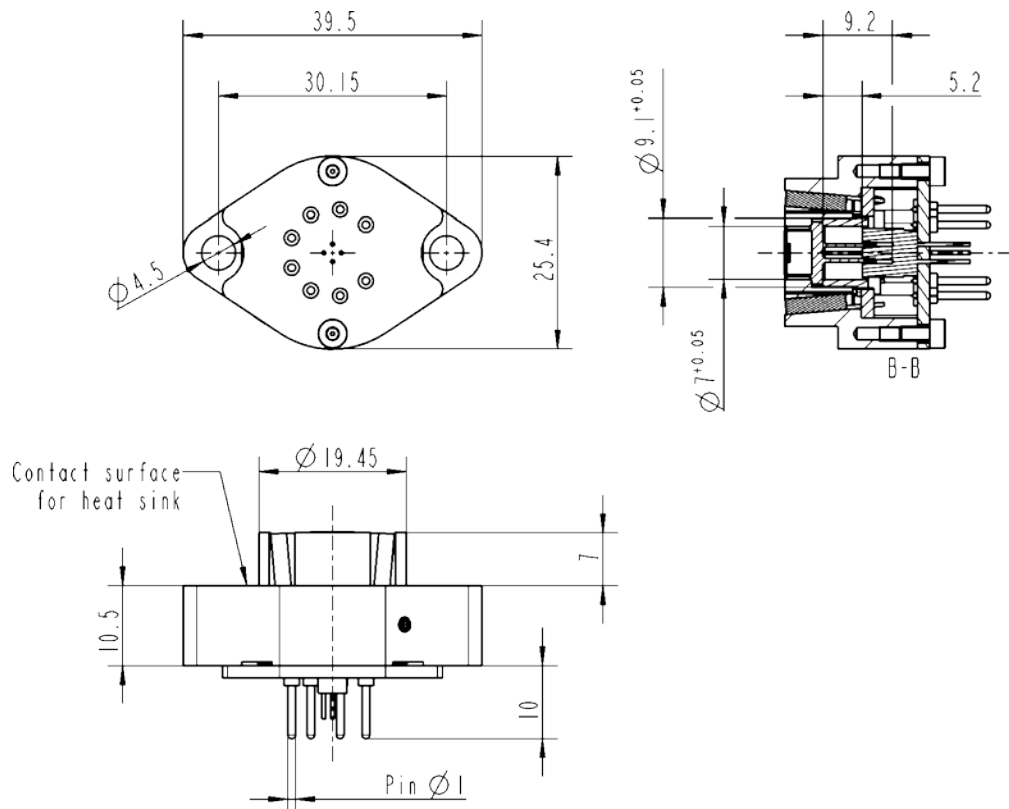

Figure 11 COLDPACK Main Dimensions

Guarantee and Service

On the following page you will find the Guarantee Conditions. Also to be found on the eagleyard Website <http://www.eagleyard.com/en/company/terms-and-conditions/>

As a first step towards obtaining technical support, please contact your local distributor or visit the support pages on our web site: <http://www.eagleyard.com/en/support/>

In case you wish to return a product for diagnosis and/or repair, please contact us prior to sending it so we can issue a Return Material Authorization (RMA) number for you.

You can contact us in the following way:

- internet: <http://www.eagleyard.com/en/support/rma-portal-for-failure-analysis-returns/>

Guarantee Conditions

1. All information concerning eagleyard Photonics GmbH's products is given to the best of eagleyard Photonics GmbH's knowledge. However, such information does not free the customer from the need to carry out its own checks and tests. The customer is obliged to check the goods (and in appropriate circumstances, to conduct any relevant tests) without delay, in order to ascertain the existence of any defects in relation to composition and fitness for purpose.
2. The customer must notify eagleyard Photonics GmbH in writing of any defects without delay, and in any event within 8 days from the date of receipt of the goods. Defects which could not be discovered within 8 days from receipt shall be notified to eagleyard Photonics GmbH within 8 days of the date on which they first became apparent. The customer shall lose its rights in relation to any defects which are not reported to eagleyard Photonics GmbH within the relevant time limits.
3. Should the customer ascertain that an incorrect quantity of goods has been delivered, then the customer shall inform eagleyard Photonics GmbH of this in writing without delay.
4. The warranty period shall commence on delivery and shall run until the end of the period prescribed by law. During the warranty period, the customer shall only be entitled to the remedies of repair and replacement, at the option of eagleyard GmbH. eagleyard Photonics GmbH has the right to repair or replace the goods on repeated occasions. No claim under a warranty may be made in the case of inappropriate use, incorrect installation, incorrect servicing and non-adherence to all relevant rules and instructions including any rules relating to safety in the workplace and laser safety. A right under a warranty will not arise where the customer makes changes to the goods or overhauls the goods without the previous consent of eagleyard Photonics GmbH.
5. Where measures taken to bring the goods into conformity with the contract fail, the customer is still entitled to exercise its statutory rights.
6. Insofar as nothing to the contrary is specified in this contract, eagleyard Photonics GmbH excludes liability for all damages (other than liability for death or personal injury), except where such damages result from intentional or grossly negligent behaviour. eagleyard Photonics GmbH is therefore not liable for physical damage to any property other than the goods themselves. In particular, eagleyard Photonics GmbH is not liable for loss of profits or other financial losses of the customer.
7. eagleyard Photonics GmbH shall not be liable for any damages which are caused by inappropriate use of the goods. eagleyard Photonics GmbH does not guarantee the suitability of the goods for any particular purpose and does not undertake any obligations relating to the provision of advice, unless this has been agreed in writing.
8. Where the customer asserts a right of retention on the grounds that the goods do not comply with the contract, it shall put all the retained monies on deposit in accordance with the procedure prescribed by law.